



TR3-Series

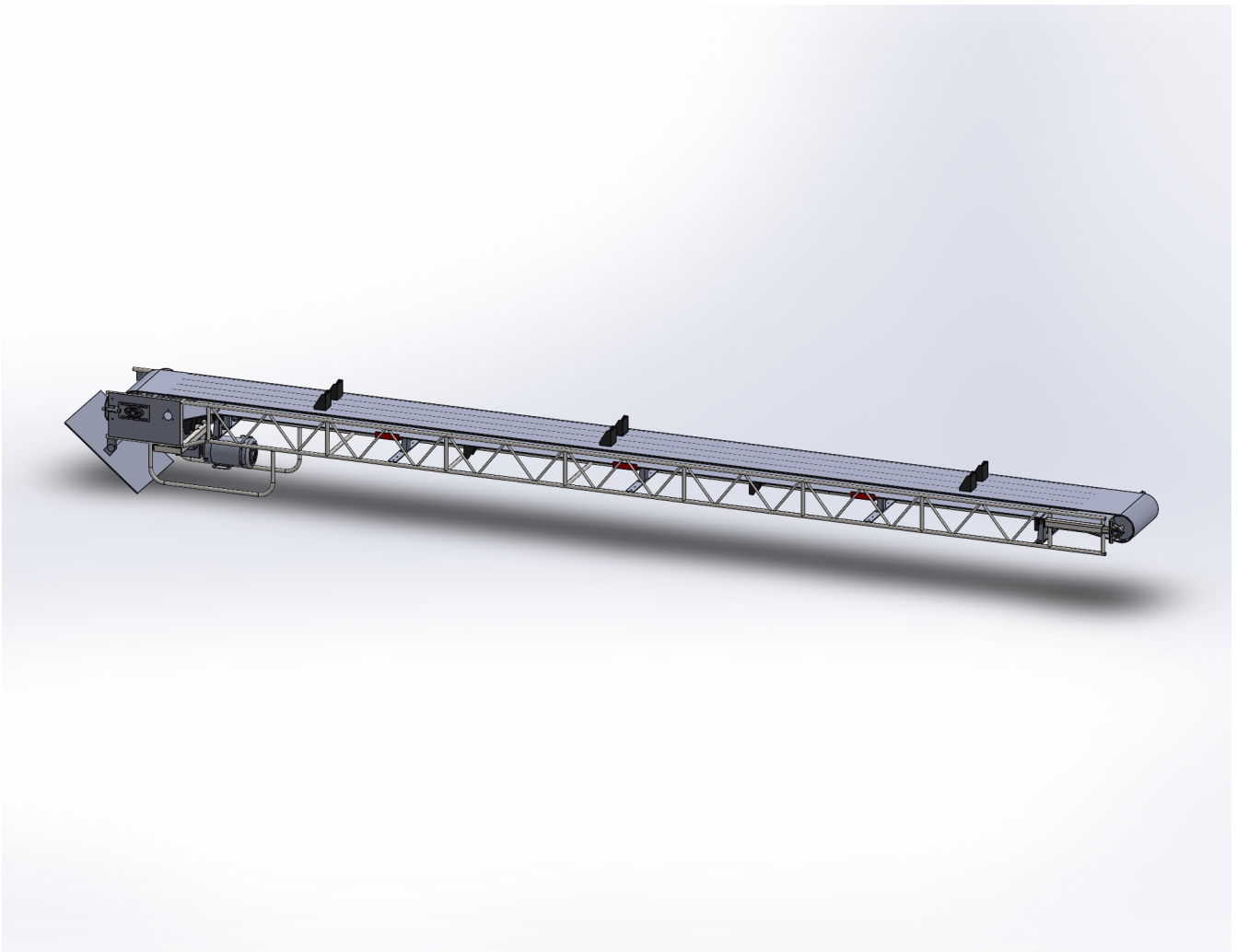

TABLE OF CONTENTS

SECTION ONE – GENERAL INSTRUCTIONS	3
GENERAL	3
WARNING AND CAUTIONS	4
WARRANTY	6
SECTION TWO – OPERATING INSTRUCTION	7
OPERATING CAUTIONS	7
OPERATING PROCEDURES	8
SECTION THREE – SERVICE AND MAINTENANCE	9
GENERAL	9
SECTION FIVE – PARTS IDENTIFICATION	11

To the operator:

This Manual is written for you. Knowing what is in it could save your life and the life of others, and protect you from injury. Read it carefully. Operate the conveyor unit only after you have received thorough training in its safe operation.

To the owner:

Redline Systems has prepared this manual to aid you in the training process. However, you are responsible for making sure the workers understand the equipment's operation and know how to use it with safety.

We highly recommend that after their initial training, workers receive periodic reviews operating and safety procedures. Your regular monthly safety meeting is a good time to have this review

SECTION ONE – GENERAL INSTRUCTIONS

GENERAL

These instructions cover the general operation of Redline's portable conveyors/elevators. A specific conveyor may have options that require different operation procedures.

Section one – General Instructions

This section contains general safety instructions and warranty. Read all instruction before operating the conveyor.

Section Two – Operating Instructions

This section contains instructions for operating your portable conveyor.

Section Three – Maintenance and Service Instructions

This section contains instructions for maintaining and servicing your portable conveyor.

Section Four – Safety and Warning Labels

This section contains information about the various safety and warning labels that come with your portable conveyor.

Section Five – Parts Identification

This section contains parts lists and diagrams for your portable conveyor

WARNING AND CAUTIONS

Since there are so many factors to consider, we cannot give you a complete list of every problem or hazard that can arise when operating a conveyor. Nevertheless, we can state certain principles. The intended use of this conveyor is to move bulk handling material. When you use the conveyor for other than its intended purpose, hazards arise. Also, conveyors have moving parts that can be exposed. Exposed parts may be hazardous if you fail to observe proper precautions.

The list below sets out and describes a variety of hazards and general cautions with which you should be familiar. These are illustrations of possible hazards that may develop as a result of improper or careless use of the equipment. This list is not all-inclusive. Therefore, avoid hazardous conduct and situations, even if they are not specifically listed.

Persons

1. Training Before Operating.

Operate the equipment only after being thoroughly trained. Since one type of conveyor unit may operate differently than another, only operate equipment upon which you have received specific training. Training should include both normal and emergency conditions. Get training in the safe operation of the equipment at least once every six (6) months. If you have not used a particular unit within the past 60 days, retrain on that unit before operation.

2. Health/Physical Requirements.

Operate the equipment only if you do not have health, physical or mental limitations that might impair safe operation. Operating the equipment; i.e. loading the conveyor with material, can require a high degree of physical exertion.

3. Caution when Lifting.

Use caution when lifting heavy objects. Failure to observe proper procedures and due care when lifting can result in bodily injury.

4. Be Careful.

Do not use the conveyor equipment in any dangerous way. Be aware of the potential dangers that can, or do exist under particular operating circumstances. Failure to exercise prudence and due care when operating the equipment is unsafe and hazardous.

5. Training for maintenance.

Only service or adjust the equipment if you have been thoroughly trained. Failure to do so is unsafe and hazardous.

6. Clothing.

Wear proper clothing when operating the equipment. Do not wear loose clothing, as it is a risk to get caught in the moving parts of the conveyor and draw you into the machinery. Also, wear appropriate personal safety equipment while operating the conveyor: Steel-toed safety shoes, hard hats and gloves, as necessary.

Conditions and Locations

1. Conveyor Maintenance

Maintain the conveyor unit properly. Correct unsafe conditions immediately.

2. Wet Conditions

Do not turn on, or plug in electrical components near water exposures or in wet conditions.

3. Secure Mobile Unit.

Only operate the conveyor when the Undercarriage and conveyor have been leveled and anchored properly. Do not operate conveyor when the undercarriage wheels are free of movement on the ground. Do not operate conveyor when transporting the equipment.

Uses

1. Transport only materials.

The conveyor's purpose is to transport material, not people. Using the conveyor to transport people is extremely hazardous and may cause injury or death.

2. Conveyor not a ladder.

Do not allow anyone to climb on the conveyor or use it as a ladder to reach higher elevations.

3. Running Conveyor.

Do not let anyone ride, stand or sit on a running conveyor.

4. Instability of conveyor.

Instability of a conveyor can result from being placed on dirt, unstable ground or another unstable support.

5. Weight limitations.

Weight limitation or load capacities of the conveyor should be observed carefully.

WARRANTY

Redline Systems, Inc. builds all of its equipment to exact specifications, and rigidly inspects it before leaving the factory. We warrant our products, for three months from the date of purchased, to be free from defects in material and workmanship, under normal use and service. Under this warranty, Redline Systems, Inc. obligation is limited to repairing or replacing, at our discretion, FOB Clearfield, Utah, USA, any part of the product that our examination discloses is defective. This warranty does not cover circumstances beyond Redline Systems, Inc's control, nor problems caused by failure to follow operating and maintenance instructions in our manuals. We make no other express warranty for this products. This warranty is in lieu of all other warranties, express or implied. Redline Systems Inc. will not be responsible for any consequential or incidental damages resulting from the sale or use of its conveyors, regardless of the cause of such damage; except, as otherwise specifically provided by law. This warranty does not cover parts not manufactured by Redline Systems, Inc., such as engines, belts, batteries, tires, hydraulic hoses, and hydraulic motors (Look to the individual warranties of their manufacturers). We will, however, help you, if need be, to settle a problem. This warranty will not apply to defects resulting from damage, alteration, lack of maintenance or misuse. If, in the opinion of Redline Systems, Inc. personnel, modifications or additions made outside our factory have affected the equipment adversely, so as to make it faulty, this warranty is void. This warranty also will be void if any parts not manufactured, or approved, by Redline Systems, Inc. have been incorporated, or if repairs are made without authorization from Redline Systems, Inc. We reserve the right to make changes in the construction or design of any product at any time without notice to any prior purchaser.

RETURNS

Redline Systems, Inc. requires that you accompany all returned merchandise by a RMA (return merchandise authority) number. Your local dealer or distributor can aid in securing warranty replacement and service. If you do not have a representative in your area, you may contact the factory directly.

SECTION TWO – OPERATING INSTRUCTION

OPERATING CAUTIONS

- 1. Do not operate the equipment until you have set up an operating safety zone around the conveyor.**
- 2. Missing Safety Device.**
Do not operate the conveyor if it is missing any guard, or other safety device.
- 3. Hands and Arms.**
Do not reach through any piece of equipment for any reason, whether it is in operation or not.
- 4. People Around the Conveyor.**
Do not let unauthorized and untrained individuals on or around the equipment. Never allow anyone to stand under the conveyor, whether it is in operation or not. Maintain the safety zone. Be especially watchful while raising or lowering the bin and or conveyor.
- 5. Unobstructed view.**
Operate the conveyor only when your view of the conveyor and the surrounding are clear and unobstructed.
- 6. Starting the conveyor.**
When starting the conveyor, notify all people in the immediate vicinity.

OPERATING PROCEDURES

1. Select a safe operation site. Set up a safety zone around the conveyor.
2. Review the warning and operating instructions contained on the sticker attached to the conveyor. Review the instruction manual if there are any questions about operating the conveyor, and get help as needed, before starting operation
3. Make sure the conveyor and undercarriage are unable to move by chocking the undercarriage wheels properly on a level surface. Make sure all pins are in place.
4. Make sure all guards are in place before operating the conveyor
5. Inspect conveyor for any hazards or interfering objects that may come in contact with the conveyor when starting the conveyor. Make sure all maintenance has been done.

Be careful not to overload the conveyor belt with the material you are trying to move.

SECTION THREE – SERVICE AND MAINTENANCE

GENERAL

This section contains instructions for maintaining and servicing Redline System's Conveyors.

1. No maintenance shall be performed when a conveyor is in operation.
2. Routine inspections, preventative, and corrective maintenance programs must be implemented
3. Refer to your engine and motor service manual for service instructions
4. Keep all exposed cylinder rods oiled to avoid rust. (For undercarriages with Hydraulic cylinder lift)
5. Check and keep all nuts and bolts tight
6. Inspect cylinder pins often to make sure the cotter pin clips have not come out.

SECTION FIVE – PARTS IDENTIFICATION

PARTS IDENTIFICATION : TR3-Series Drive End

TR3-Series Drive Pulley End

NO.	Part No.	Description
1	D1602-16	D Drive Drum for 16" belt (weldment)
2	16BJA	#52 MSTU 4-Bolt Plate Flange w/ Adjuster Bolt
3	16AIA	1" Insert Bearing
4	17BAA	40B16 x 1-1/8" Bore Sprocket w/ 1/4 Key
5	17BAB	40B35 x 1" Bore Sprocket w/1/4" Key
6	237-20	20:1 x 237 Gearbox Reducer 1-1/8" output shaft 56C
7	17AAB	#40 Master link
8	17AAA	#40 Chain
9	19REC	TR3 Chain Guard
10	5BDC	D Adjuster bracket
11	20TR3-1616	Complete Replacement belt for TR3-1616
12	124AFB	FBR Belt Cleat
13	20KA	125 Belt lacing Kit for #52 x 16"
14	D109	Forward/Neutral/Reversing Drum Switch
15	D110A	Control Rod for TR3-1616
16	5MBC	24" X 24" X 1/4" Plate - TR3 Base Plate
17	5MBD	Axle Pin for TR3 Baseplate

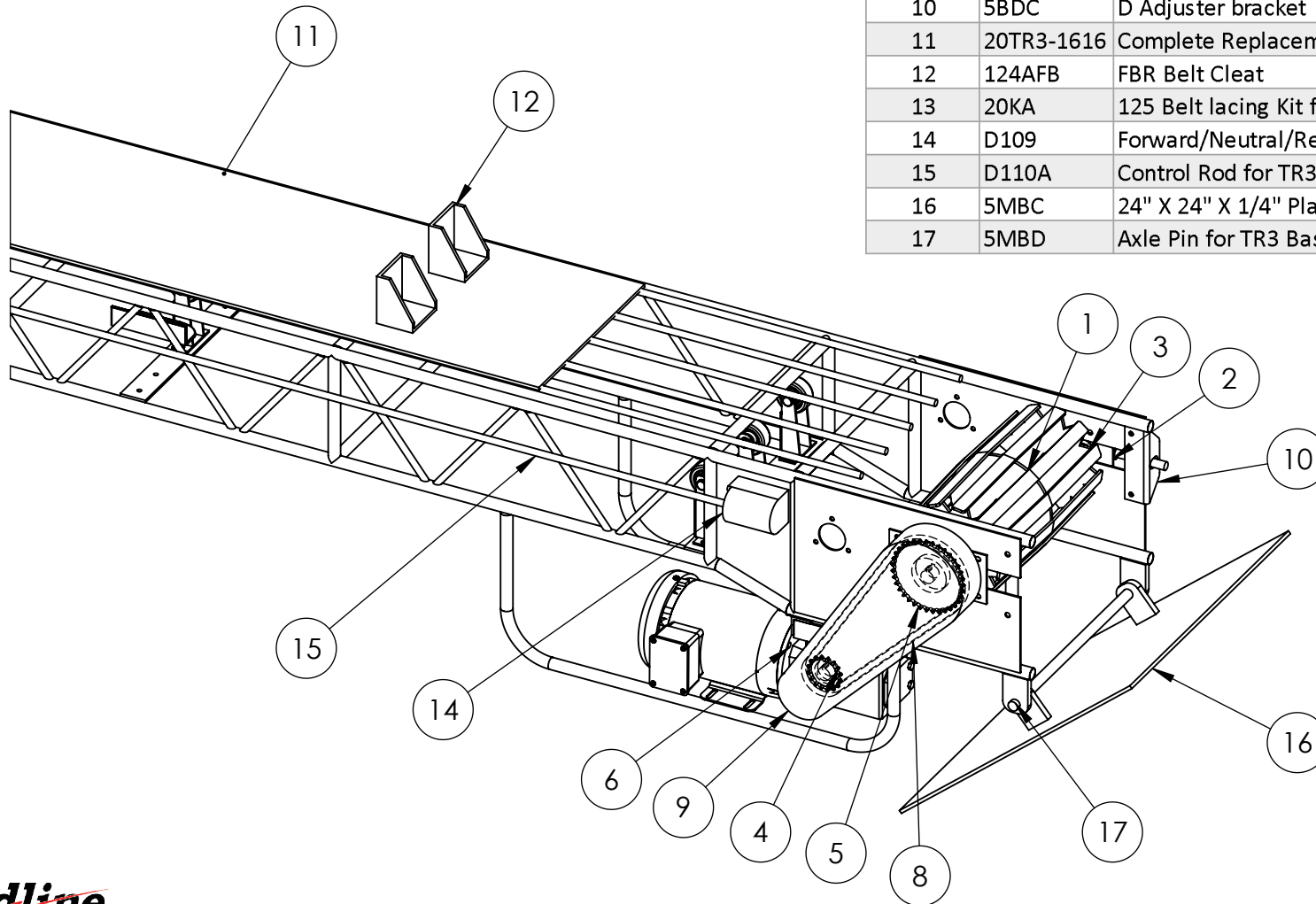

PARTS IDENTIFICATION : TR3-Series Tail End

TR3-Series Tail Pulley End

NO.	Part No.	Description
18	D1603-16	D Tail Drum for 16" belt (weldment)
19	UCP 205-16	1" Bearing Normal-Duty Pillow Block Setscrew Lock
20	132AFB	FBR Return Roller Assembly (Bracket, Roller, Pin)
21	133AFB	FBR Tracking Angle w/Bolts

