

ADT-Series

Heavy Duty Truss Frame

3D Model



SCAN ME



ADT-Series Conveyor

With its heavy-duty truss frame, the ADT-Series is the best option for applications that require high volume throughput. Its adaptable design accommodates virtually any incline, power requirement, or bulk material type.

Belt Widths

18" | 24" | 30" | 36" | 42" | 48"

Applications

- Industrial
- Utility
- Manufacturing
- Processing
- Bulk Material Handling

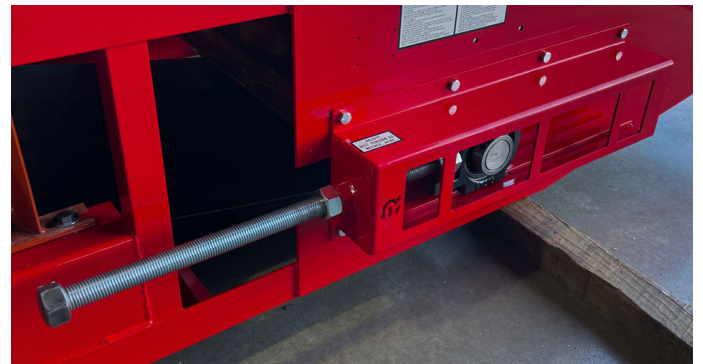
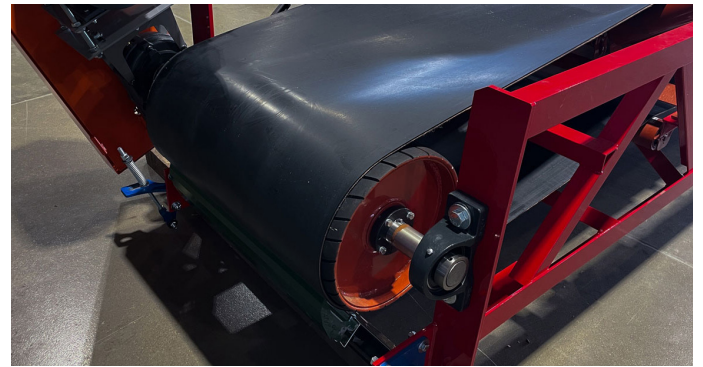

Belting

Additional belt options in full catalog.



Smooth-Top



Cleat Top



Steep Climb



Food Grade

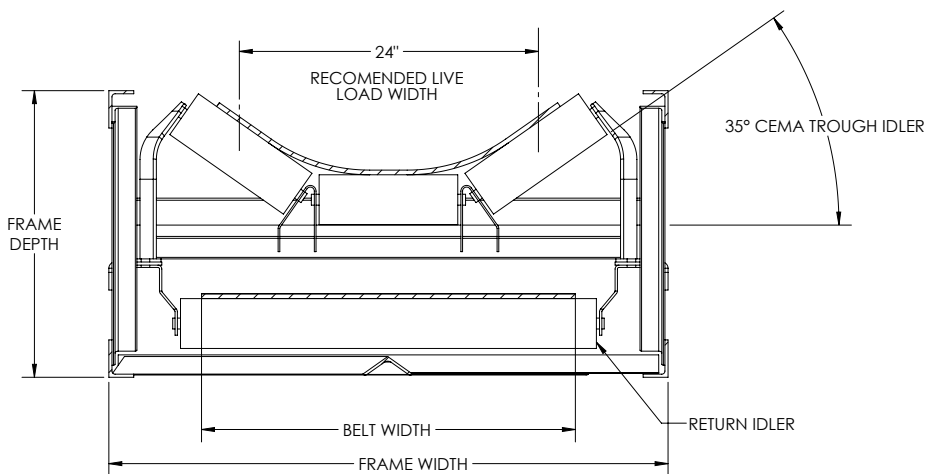

Cross Sectional View

Power Supply

- Single Phase Electric
- Three Phase Electric
- Gas / Diesel
- Hydraulics

Construction

- Heavy-Duty Truss Frame
- Powdercoated Finish
- Adjustable Belt Take-up
- Galvanized Frame (option)

Accessories

- Feed Hoppers
- Belt Cleaners
- Controls
- Variable Speed Control
- Support Legs
- Portable Carts
- Containment Side Skirting
- Discharge Chutes
- Safety Pull Chord E-Stop
- Special Guarding
- Belt Covers

Bed Profile Options

